

High Volume Cement Skin Line

Panel size 4' x 8' (1.22 x 2.44 m)
(longer optional)

Capable of producing SIPs with various skins including OSB and CEMENT skins

Description:

Lamination Process: A stack of skins is placed on each of the two in-feed tables. The machine feeds the skins into the assembly table, applying fast glue and water mist. The foam feeder inserts the solid foam core and the skins are automatically sandwiched together. The machine is adjustable to different positions of skins vs. core. The assembled panel travels to the hydraulic press, where it is pressed for 2.5 minutes depending on the speed of the glue used (24 panels per hour or up to 1,536 sq feet per hour at 16 ft length). SIPSTECH's automated and streamlined lamination process allows the use of fast glue for shorter cycle times.

Shop Layout:

The lamination line requires approximately a 30 by 45 foot area (4 x 8 ft panels). Additional space will be required for the optional cutting saw or for manual fabrication tables, for storage and for material inventory. See the diagram below for a typical shop configuration, although other variations are possible to suit client's needs.

Options:

- Larger Panels: The basic line will produce 4' x 8' Structural Insulated Panels up to a thickness of 12.25", using cement, OSB or other approved skins. SIPSTECH can also provide this line with the capability of producing panels of greater length—up to 4' x 16'.
- Cutting Saw: Lines can be equipped with a saw to cut panels into any required length, at a cost of \$20,000 to \$60,000.

- CNC Cutting Table: SIPSTECH's automated cutting table has been designed specifically for the SIPs industry, and provides the precise, repeatable and efficient production needed by high volume builders.
- SIPSTECH can also provide wall handling equipment, which will allow finishing either in the horizontal or vertical position, again depending on the client's needs.

Price: All prices are US dollars, FOB our plant near Calgary, Alberta, Canada, net of all taxes and duties.

Price includes:

- Bead Glue Applicator
- Skin Feeders
- EPS feeder
- Lamination Table
- Hydraulic Press
- Unloading Table
- Installation**
- Training on equipment use

The production capacity can be doubled by adding a second press with additional handling equipment.

**** The client is responsible for the travelling and accommodation expenses and any surcharge for different power requirements than in North America.**

WWW.SIPSTECH.COM

P (403) 277.4000 F (403) 277.4001 mt@ sipstech.com
Canadian mailing address: 1420 101 Street S.W. • Calgary, Alberta • CANADA • T3H 3Z4

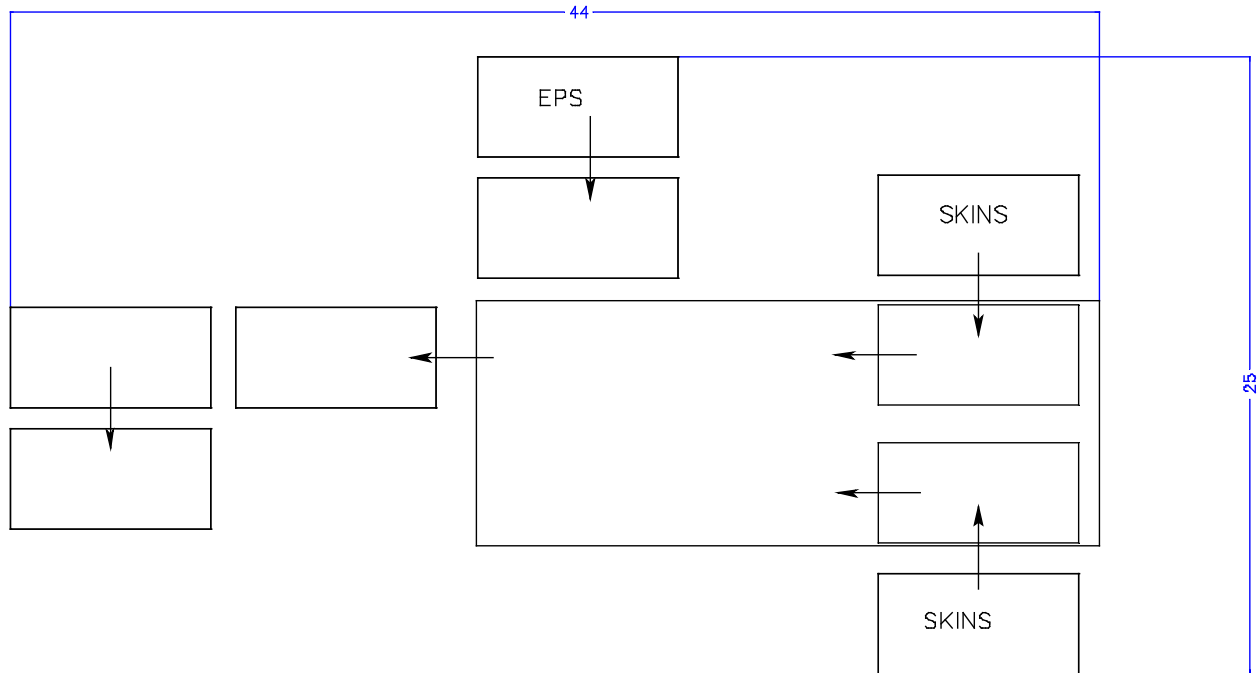

Sketch of an Ideal Plant Layout. Sizes are for a production line capable of producing 4' x 8' panels. For longer lines, add 6' of length for each 1' extension to panel size.

WWW.SIPSTECH.COM

P (403) 277.4000 F (403) 277.4001 mt@ sipstech.com
Canadian mailing address: 1420 101 Street S.W. • Calgary, Alberta • CANADA • T3H 3Z4